

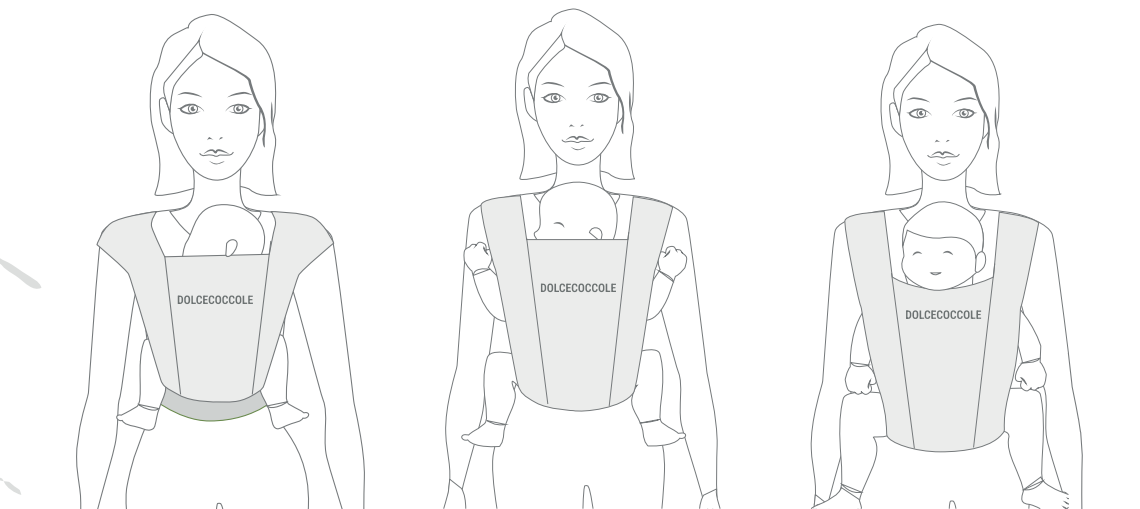

DOLCECOCCOLE

INSTRUCTION MANUAL



BABY WRAP CARRIER

WRAP YOUR BABY IN LOVE

ergonomic | lightweight | skin-friendly

Check out more tips and videos.
www.dolcecoccole.com



IMPORTANT! READ CAREFULLY AND KEEP FOR FUTURE REFERENCE

CONTENTS

- 1 DOLCECOCOLE baby wrap carrier details
- 2 Risks, warnings and safety precautions
- 3 Cleaning instructions
Ages and stages - General guidelines
- 4 1. Baby positions - checklist & tips
- 5 2. Newborn mode - facing in <23 in | <58.4 cm
- 6 3. Baby mode - facing in <23+ in | <58.4+ cm
- 7 4. Baby mode - facing out 26+ in | 66+ cm

BABY WRAP CARRIER DETAILS

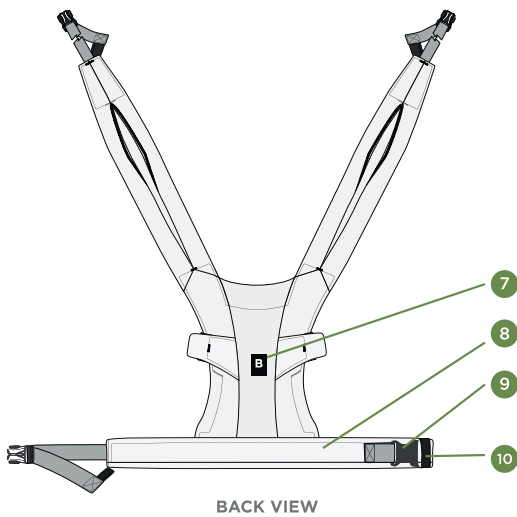
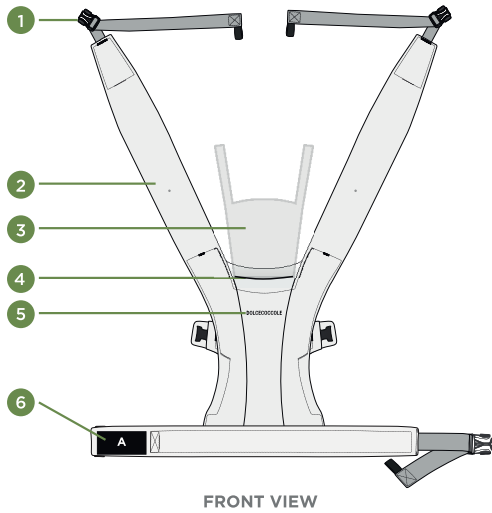

- 1 cross strap buckle
- 2 cross strap
- 3 sun protection and support for baby's head
- 4 head and neck support
- 5 DOLCECOCCOLE logo
- 6 label A
- 7 label B
- 8 waistbelt
- 9 waistbelt buckle
- 10 safety elastic loop

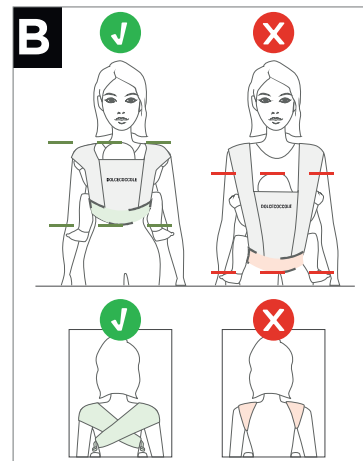
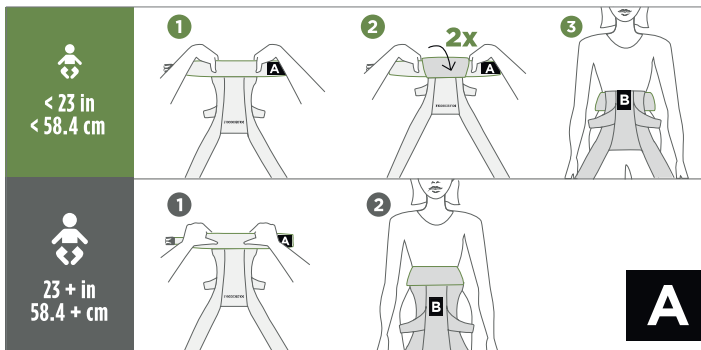

RISKS, WARNINGS AND SAFETY PRECAUTIONS

IMPORTANT! PLEASE READ CAREFULLY AND KEEP FOR FUTURE REFERENCE

⚠ ATTENTION: RISK OF SUFFOCATION AND FALLING

RISK OF FALLING - Babies could fall out of the baby carrier, especially if the leg openings are too large.

- Adjust the leg openings to fit the baby's legs snugly.
- Check the security of all fastenings before each use.
- Take special care when bending over or walking.
- Do not bend at the waist: bend at the knees.
- DO NOT USE the carrier with babies weighing less than 7.0 lbs (3.2 kg).

RISK OF SUFFOCATION - Babies younger than 4 months old could suffocate with this product if their face is pressed too tightly against your body.

- Do not tie the baby too tightly against your body.
- Allow space for the baby to move their head.
- Ensure the baby's face is not obstructed at any time.
- Do not let the baby sleep in the front position facing outward.
- When breastfeeding the baby in the baby carrier, always reposition the baby correctly after nursing to ensure the baby's face is not pressed against the mother's body.

ATTENTION

- The baby should face the adult until they can hold their head up on their own.
- Only use the front-facing position when the baby has strong and consistent neck and head control.
- To avoid any risk of falling, ensure the child is properly positioned in the baby carrier.
- Keep your child under supervision at all times and ensure their mouth and nose are not obstructed.
- For premature babies, low-weight babies, or children with medical issues, consult a healthcare professional before using this product.
- Make sure your child's chin is not pressed against their chest, as this can affect their breathing and cause suffocation
- You could lose balance due to your own movement or the child's movement.
- Be careful when bending or leaning forward or to the sides.
- This baby carrier should not be used during sports activities such as running, cycling, swimming, or skiing.

USAGE PRECAUTIONS FOR THE DOLCECOCCOLE BABY WRAP CARRIER:

Read all instructions before assembling and using the baby carrier. Never leave a baby unattended in the Dolcecoccole baby carrier. Your baby's head should be supported by the head and neck support panel until the baby demonstrates strong and consistent head and neck control. Never use a baby carrier if you have balance or mobility issues due to physical exertion, drowsiness, or health problems. Never use a baby carrier while performing activities like cooking or cleaning that involve handling a heat source or exposure to chemicals. Never wear a baby carrier of this type while driving or as a passenger in a vehicle. If you drink hot beverages while using the carrier, be careful not to spill the liquid on the baby. Never unbuckle the waist belt while the baby is inside. Be aware that as the baby becomes more active, the risk of falling from the carrier increases. Only carry one child in the baby carrier. Also, do not use/wear more than one baby carrier at a time. There should always be at least two finger widths of space in front of the baby's chin. The risk of suffocation is higher in premature babies, babies with respiratory problems, and babies under 4 months old. Make sure to properly position the baby in the product, not forgetting the leg position. It is necessary to check the baby's position regularly to ensure they are properly seated in the carrier, centered, with legs apart and bent, and head upright, and not too low or leaning to one side. The baby's legs and feet should be checked frequently while the baby is in the carrier to ensure the limbs' movement is not restricted. Keep the buckles fastened when not using the carrier. Regularly inspect the carrier for signs of wear or damage. Check all buckles, snaps, straps, and fasteners are in good condition before each use. Look for any ripped seams, torn straps, or broken fabric or fasteners before each use. Never use a carrier if the fabric, fasteners, or buckles are damaged. Remove the baby from the carrier before changing the carrier's position. For smaller babies or adults with a long torso, the belt should be worn higher so that the baby's head is close enough to kiss when carried in the front position. The baby carrier should not be used until the wearer understands the instructions and safety features and feels comfortable and confident using the baby carrier. This baby carrier should only be used by healthy adults. If you experience shoulder, back, or neck pain while using the baby carrier, stop using it and consult your doctor. Choose appropriate materials to dress the child. Check the child's body temperature by touching their body with your hand. Age references are general guidelines, as each baby's development is different. Ensure your baby meets the specific usage requirements. Contact a Dolcecoccole customer service representative for additional assistance if needed. Instructional videos and additional tips can be found at www.dolcecoccole.com.

Disclaimer: Dolcecoccole only uses the safest and highest quality dyes to ensure the product retains its color; it does not contain harmful chemicals. There is always the possibility of colors fading with washing. Dolcecoccole is not responsible for color fading.

CLEANING INSTRUCTIONS:



Machine Wash Cold



Air Dry



No Bleach



Do Not Iron



Do Not Dry-Clean.

AGES AND STAGES - GENERAL GUIDELINES

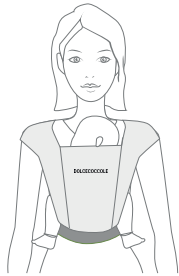

NEWBORN - INWARD - FACING

< 23 in | < 58.4 cm
0-2 m
Min. 7 lbs | 3.2 kg

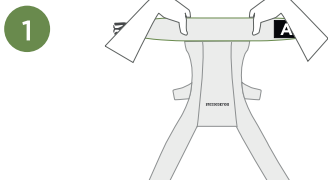

2x

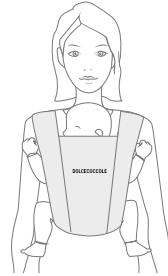
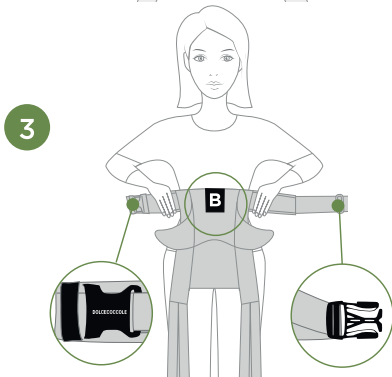
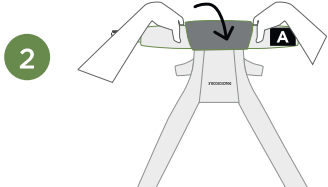

BABY - INWARD - FACING

23+ in | 58.4+ cm
> 2 m

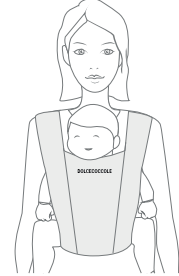

FRONT CARRY OUTWARD - FACING

26+ in | 66+ cm
> 5 m

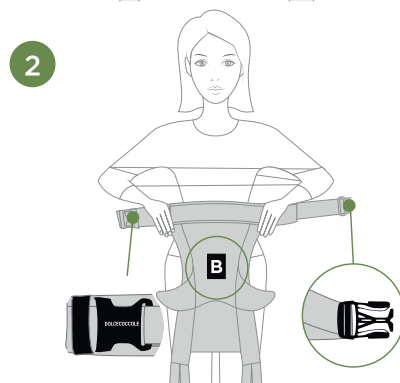
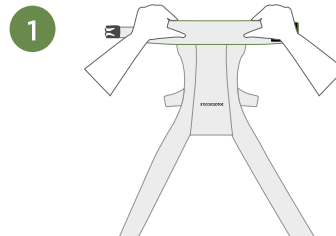

1 BABY POSITIONS - CHECKLIST & TIPS

1A The baby's head should be supported at mid-ear level from 0-4 months or until the baby has head/neck control.

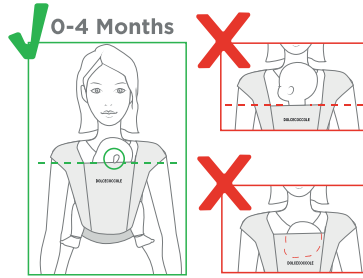

1B Open airway and visible face at all times

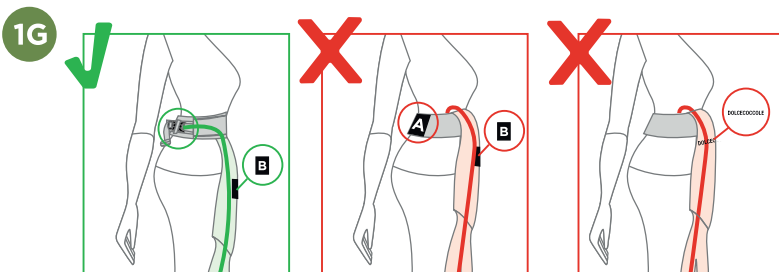
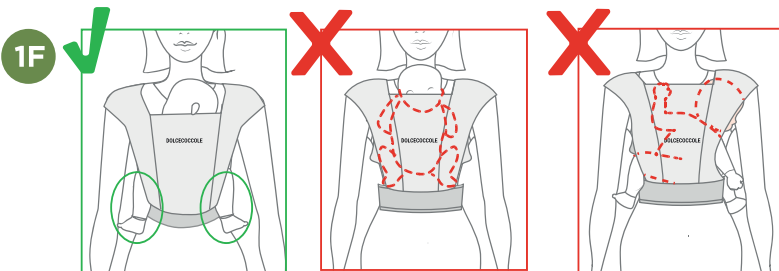
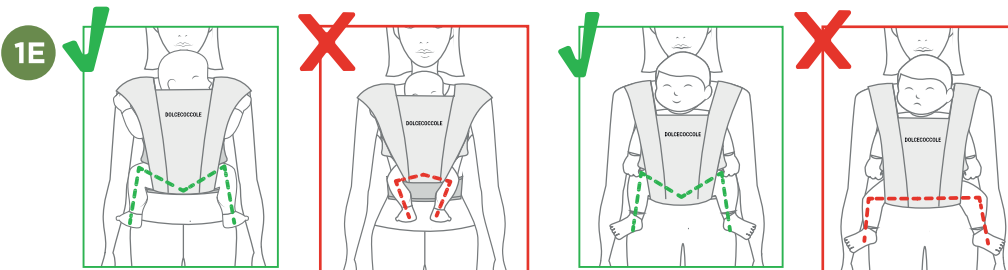
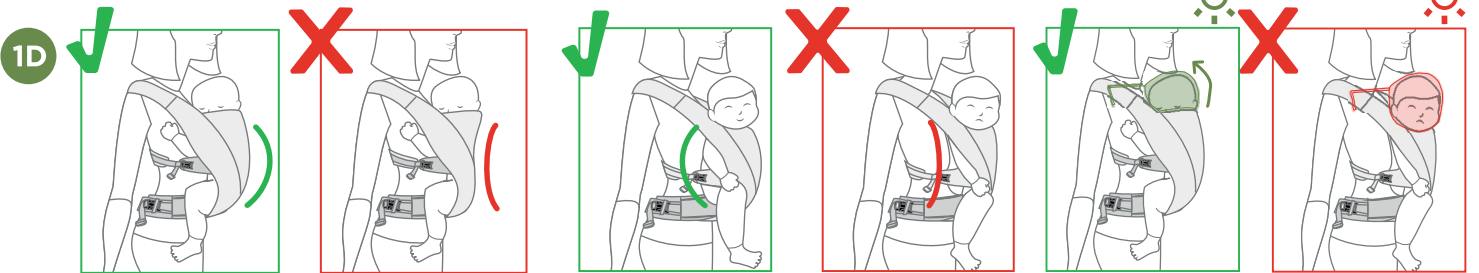
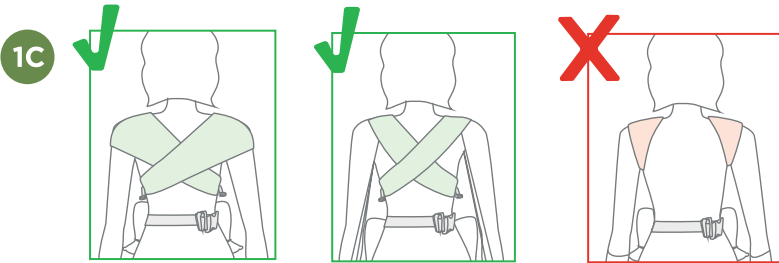
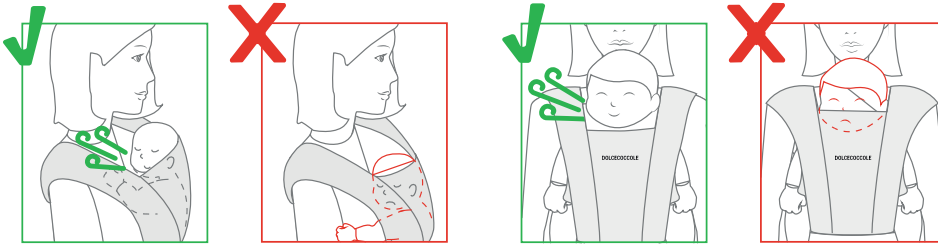

2

NEWBORN MODE - FACING IN

<23 in | <58.4 cm

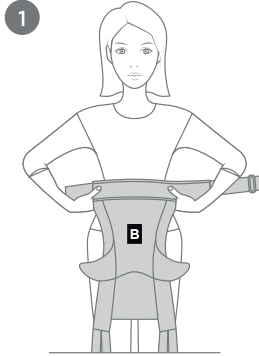
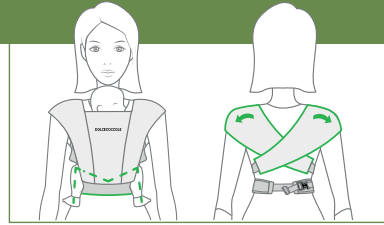

Fold the belt inward twice.

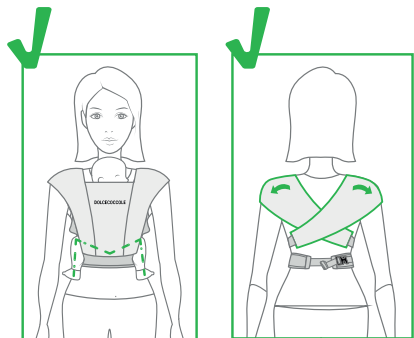
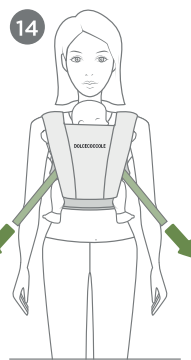
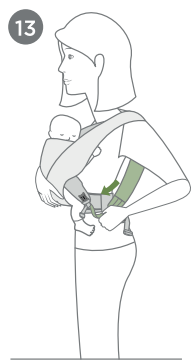
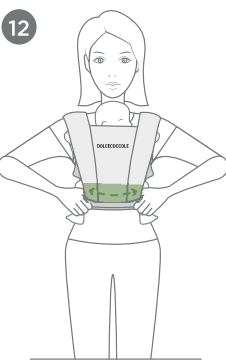
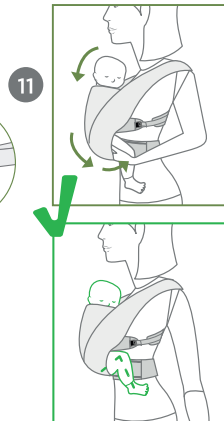
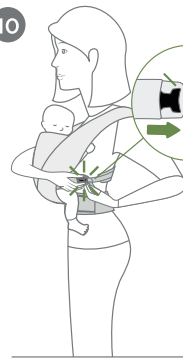
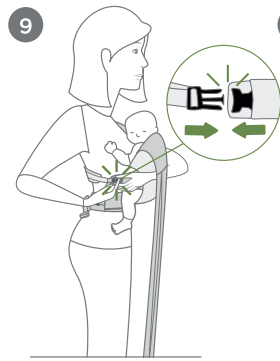
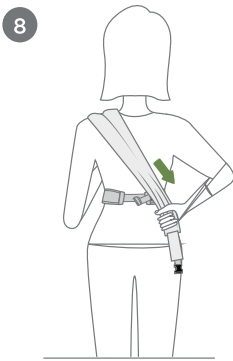
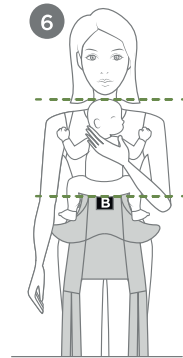
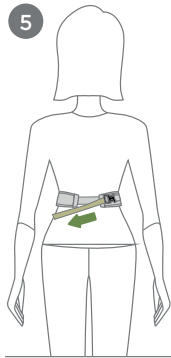
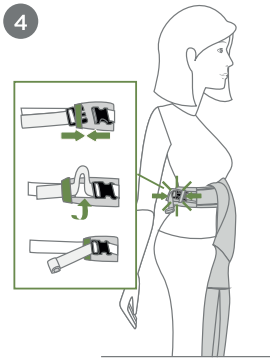
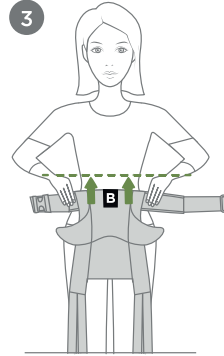
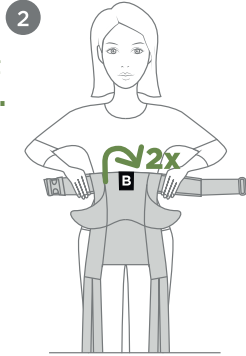

3 BABY MODE - FACING IN

23+ in | 58.4+ cm

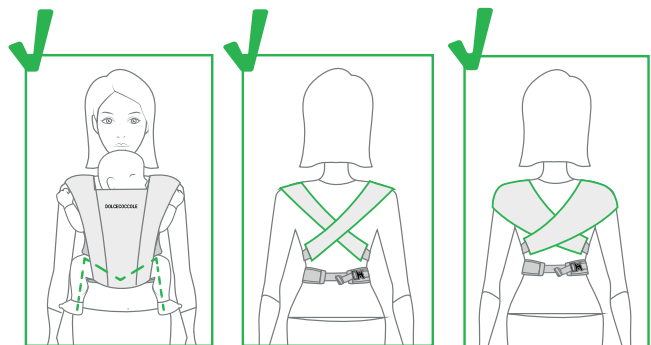
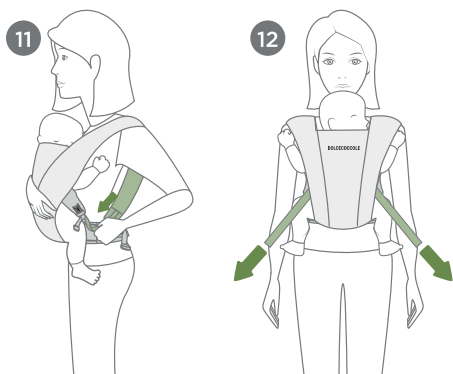
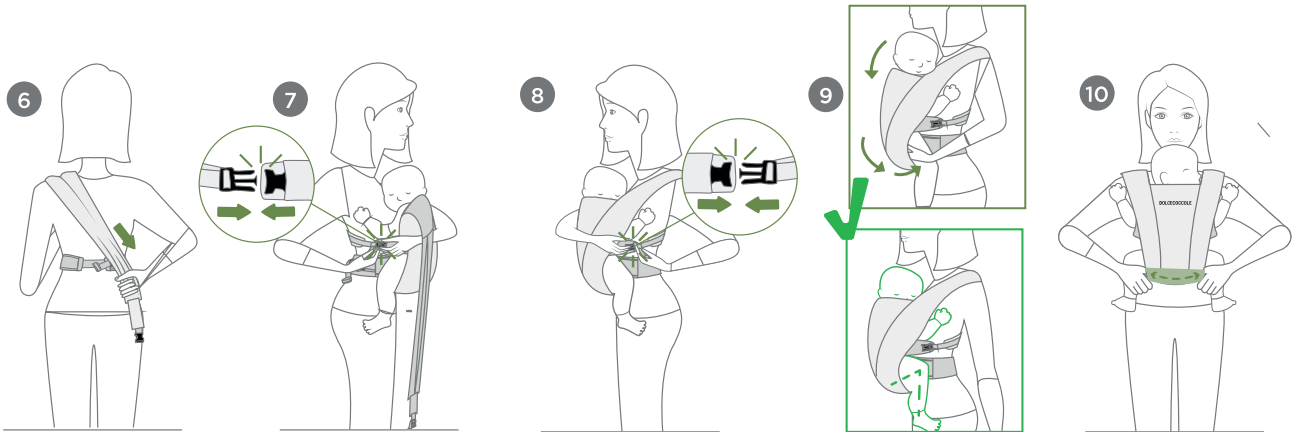
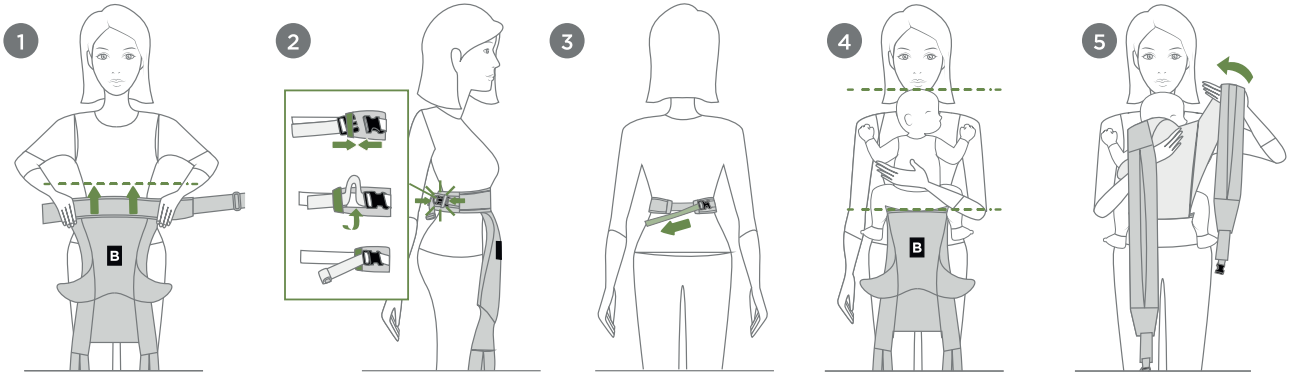
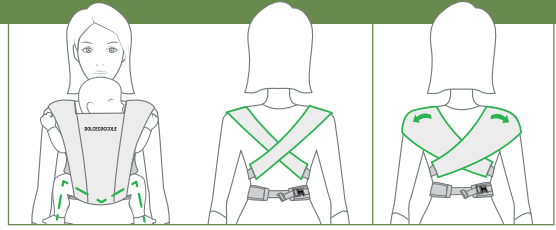

4 BABY MODE - FACING OUT

26+ in | 66+ cm

The baby must have strong head/neck control. The head must be higher than the back panel.

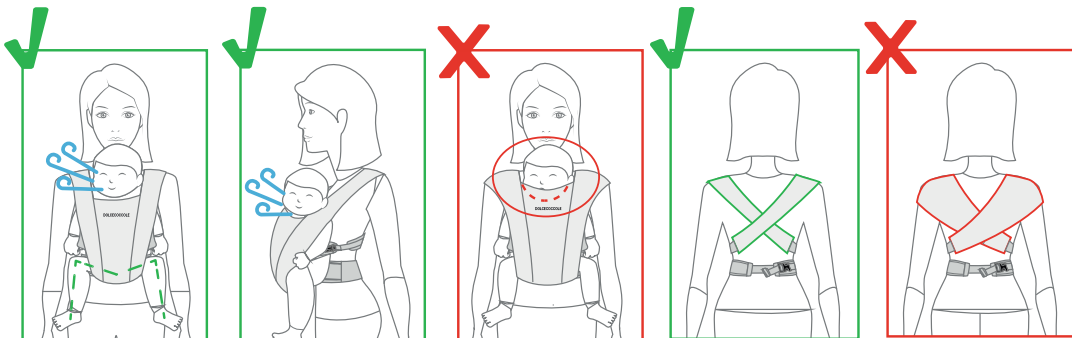
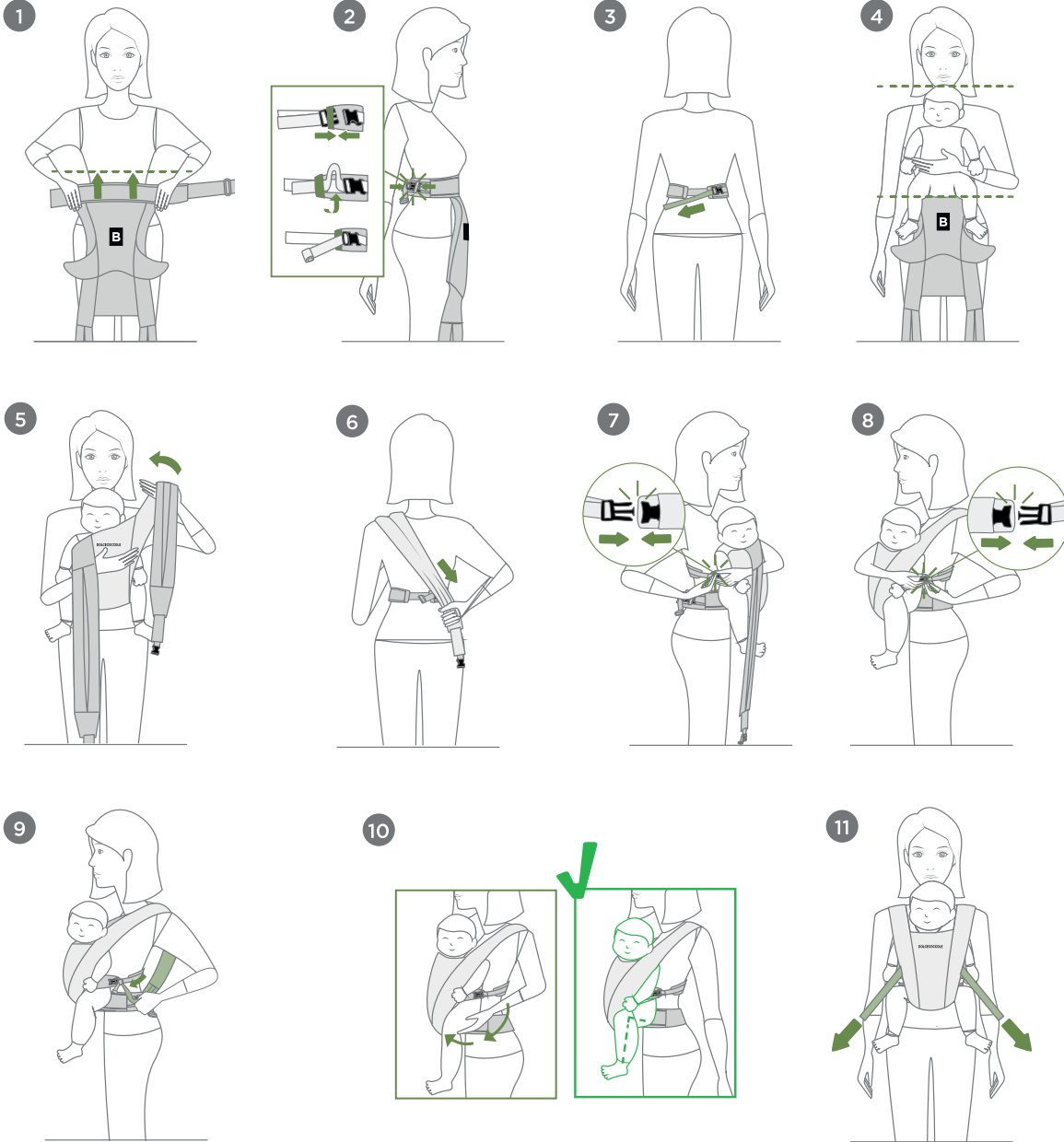
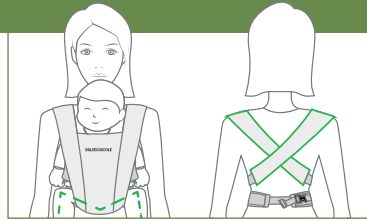



DOLCECOCCOLE